

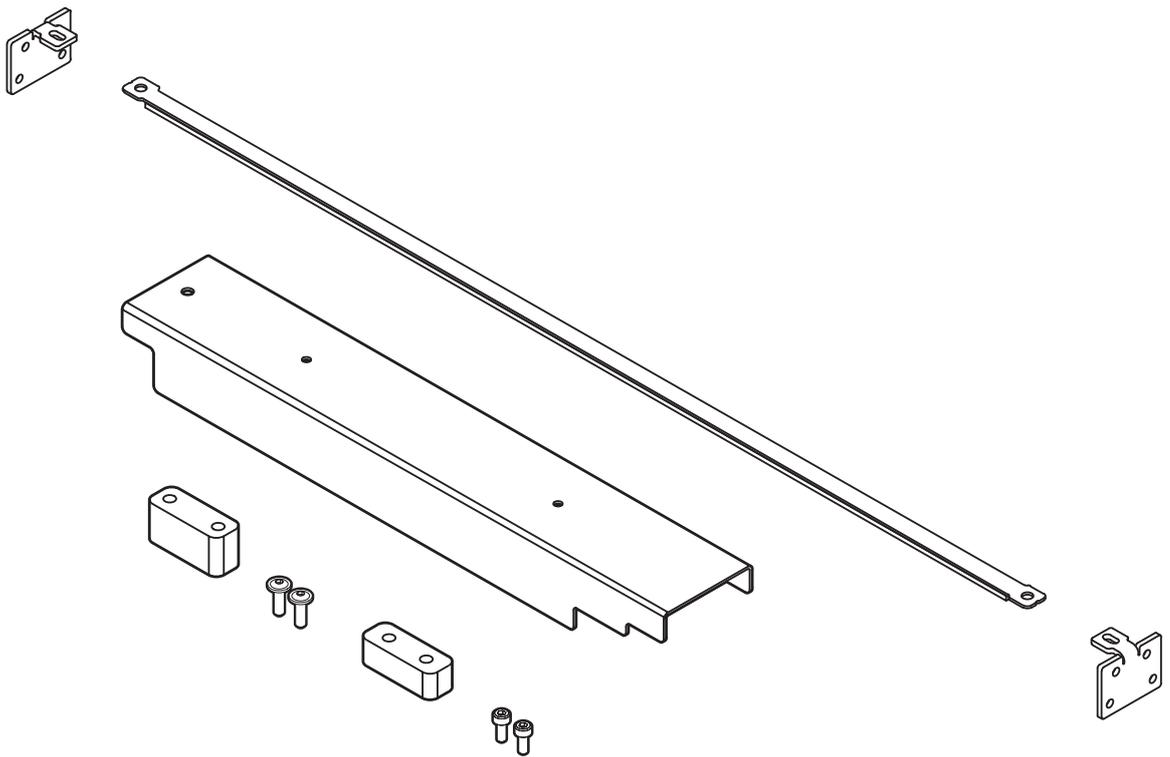

RECOATER STRIP RETROFIT

ASSEMBLY MANUAL



Version 04/2024/EN





LIST OF ELEMENTS:

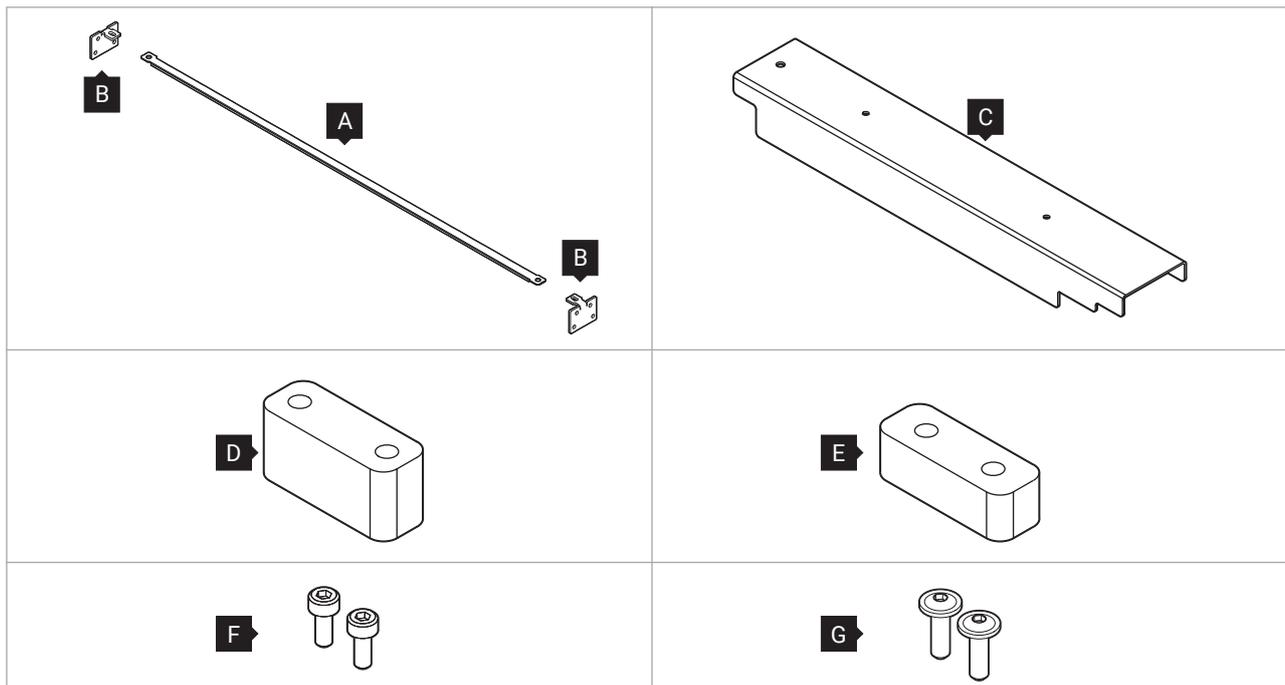

* If the Recoater already has a replacement tribotape for the Levelling slider, it is unnecessary to replace it with the one included in the kit.

A	Recoater strip	1 pc	B	Angle brackets	2 pcs
C	Black cover	1 pc	D	Driver slider	1 pc
E	Levelling slider*	1 pc	F	M3x6 screws	14 pcs
G	M3x8 black screws	2 pcs			

You will need:

- Allen key 2.0, 2.5, 3.0, 4.0 mm
- Wrench/socket wrench 5.5 mm
- Brush or compressed air



1.1 ADAPTATION OF THE RECOATER



ATTENTION!

Beware of sharp edges which can cause body cuts and injury.

1. Choose **UNLOCK LID** on the screen.
2. Push on the lid and pull it up using the lid handle. Remember, you only have 10 seconds to open it before the lock activates again.
3. Clean the print chamber if needed.
4. Go to the **MAINTENANCE** and then the **CONTROL PANEL** tab.
5. Use the steering arrows to position the Recoater in between the Beds.
6. Using a 2 mm allen key, unscrew both screws on the Recoater cover (fig. 1).
7. Gently remove the black cover from the Recoater (fig. 2).

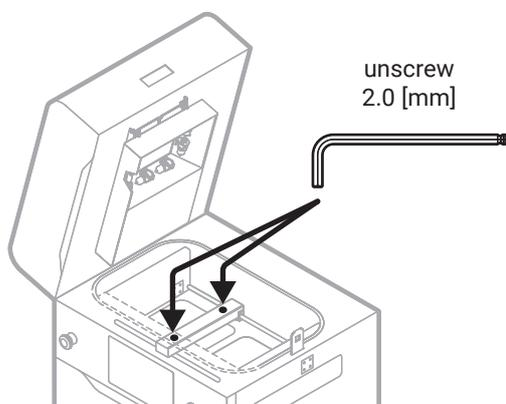

Fig. 1 Removing the screws from the Recoater cover.

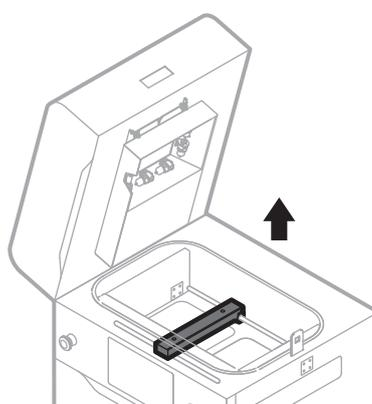

Fig. 2 Removing the black cover.

8. Using a 2 mm allen key, unscrew the screws on the Recoater cord mounting plate on the left and right sides (fig. 3).
9. Grab the cord from both sides and remove it from the knurled roller wheel.
10. Drag out the end of the cord (without spring) above the Recoater's roller. At first the mounting plate, then the ending, through the gap between the rotary shaft and Recoater housing. Be careful not to touch the roller (fig. 4).
11. Remove the second plate (with spring) from the socket.

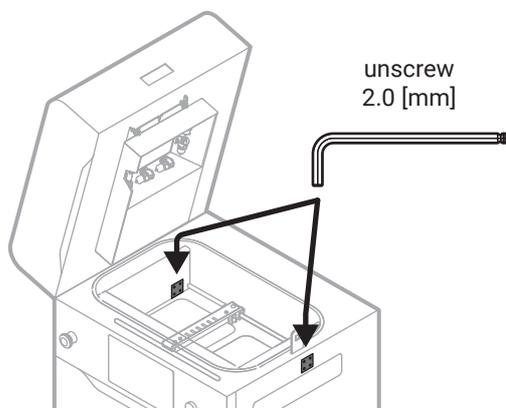

Fig. 3 Unscrewing the screw of the Recoater cord.

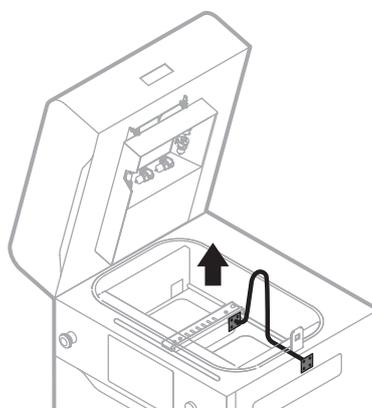

Fig. 4 Dragging out the plate without spring above the Recoater's roller.

12. Using a 4 mm allen key unscrew the two screws holding the Recoater to the bearing (fig. 5).
13. Take out the Recoater. Set the metal spacer aside.

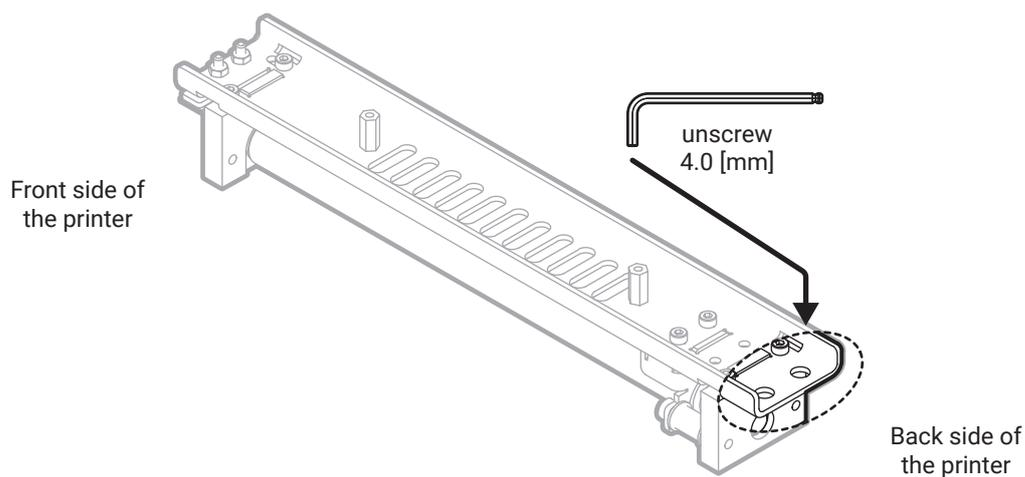

Fig. 5 Removing the Recoater.

14. Using a 5.5 mm wrench loosen the two screws of the Tribotape on the left side of the Recoater (fig. 6).
15. Remove the Tribotape (fig. 6).

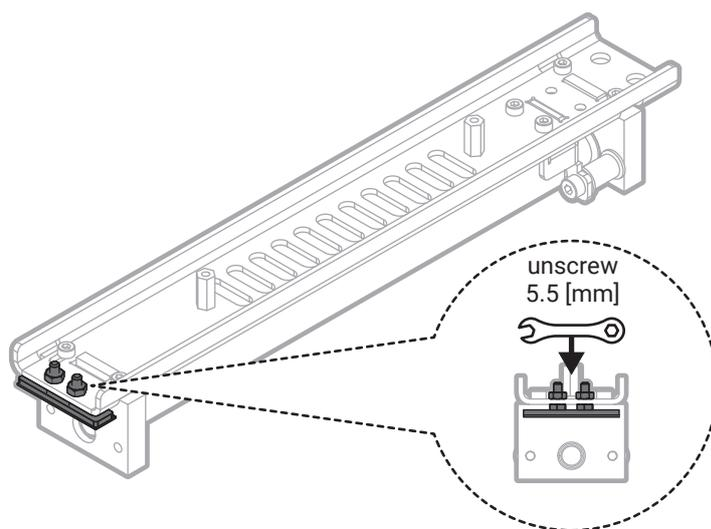

Fig. 6 Removing the left Tribotape.

16. Clean the surface of the Recoater (Isopropyl alcohol or vacuum cleaner).
17. Screw the Levelling slider in place of the Tribotape. Use the two M3x6mm screws from the supplied kit and the 2.5 mm allen key (fig. 7).

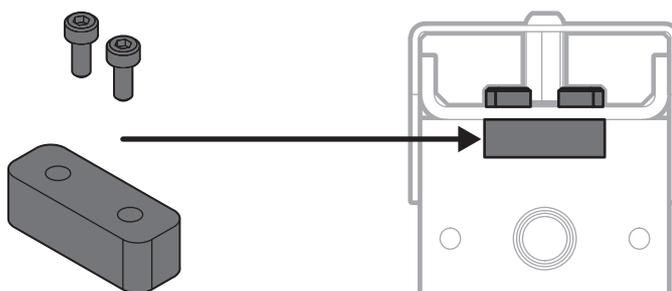

Fig. 7 Screwing the Levelling slider to Recoater.

18. Using the 3 mm allen key unscrew the two roller tracing wheels for the drive cord (fig. 8).

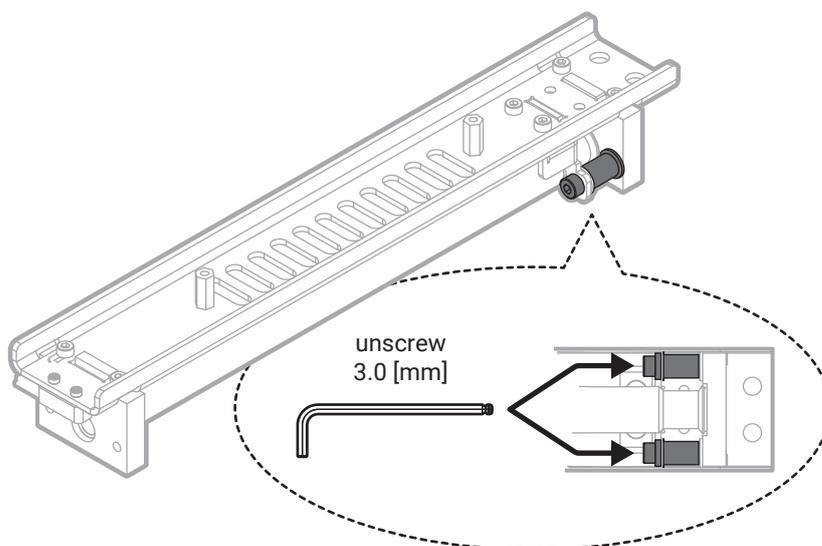

Fig. 8 Removing two roller tracing wheels.

19. Using a 2.5 mm allen key loosen the two screws of the Recoater base on the right side of the Recoater (fig. 9) and remove it.

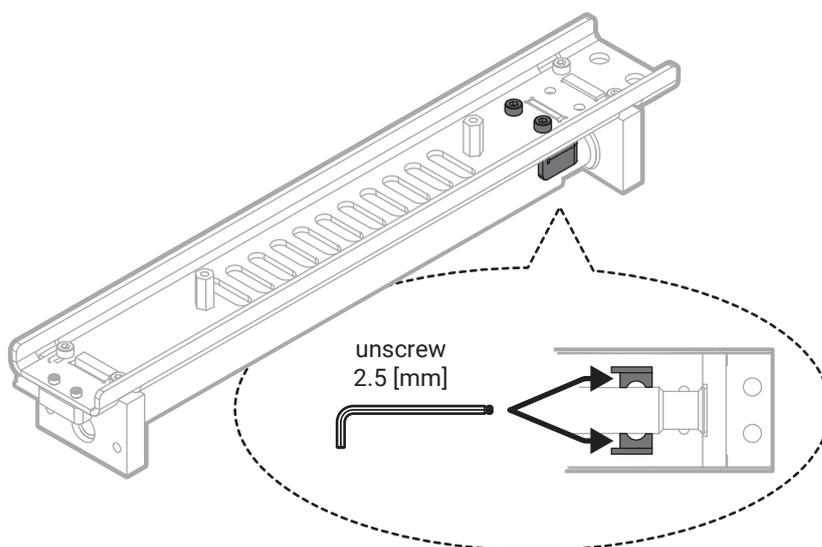

Fig. 9 Removing the Recoater base.



20. Clean the surface of the Recoater (alcohol or vacuum cleaner).
21. Screw the Driver slider into the recess, above the knurled roller. Use the two M3x6mm screws from the supplied kit and the 2.5 mm allen key (fig. 10).

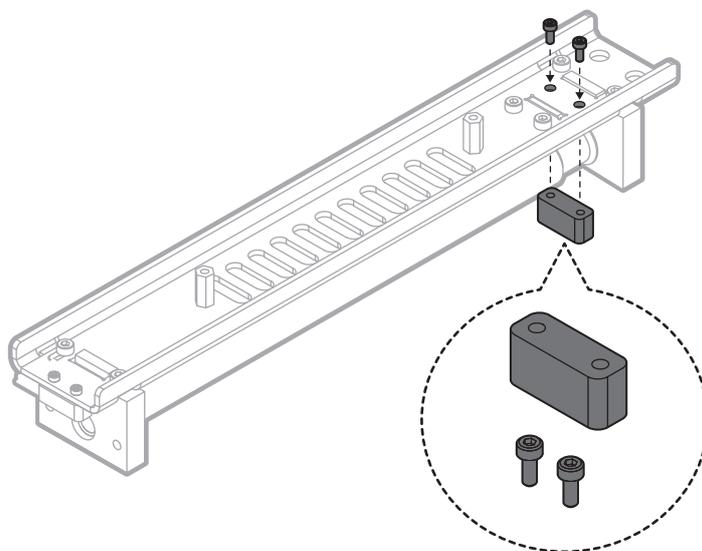

Fig. 10 Screwing the Driver slider to Recoater.

22. Place a metal spacer on the Recoater bearing and then reassemble the Recoater.
23. Using a 4 mm allen key and two M6x10 screws with a serrated washer, screw the Recoater onto the bearing.
24. Using a 2 mm allen key and two M3x8 screws, fasten the black cover onto the Recoater (fig. 11).

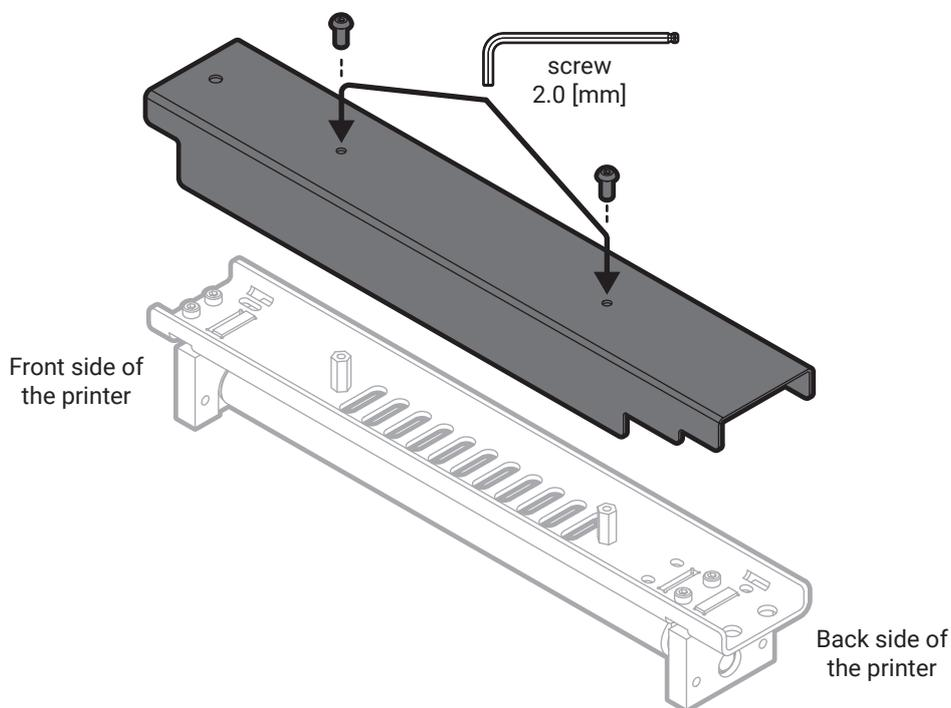

Fig. 11 Installing the new Recoater black cover.



1.2. RECOATER STRIP INSTALLATION

1. Take the two angle brackets holding the Recoater slider out of the box.
2. Screw the two angle brackets in place of the previous plates (fig. 12). Use four M3x6 screws per bracket and a 2.5 mm allen.

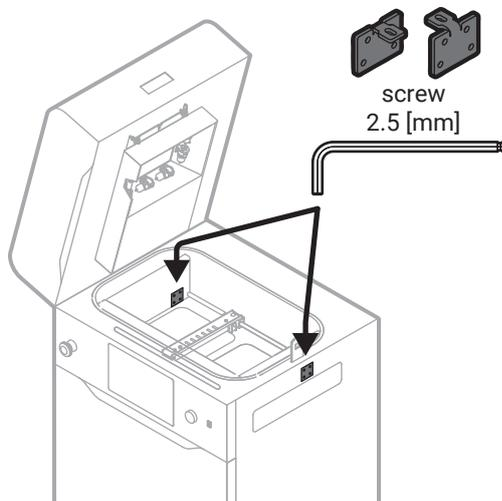

Fig. 12 Mounting the angle bracket to print chamber housing.

3. If you do not have enough space, move the Recoater to the opposite side using the steering arrows on the screen.
4. Remove the Recoater strip from its packaging. Check that it is not damaged.
5. Slide the Recoater strip into the gap between the knurled roller and the Driver slider (Fig 13 & 14).
Don't bend the strip too much - it might break!

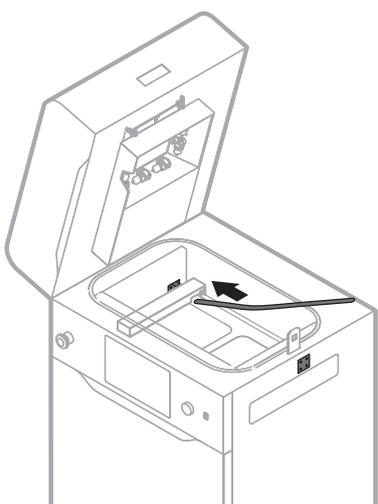

Fig. 13 Inserting Recoater strip to Recoater part 1.



Fig. 14 Inserting Recoater strip to Recoater part 2.



6. Mount the end of the Recoater strip under the angle bracket (fig. 15).



Fig. 15 Positioning the Recoater strip.

7. While holding the Recoater strip, position the Recoater in the middle, between the beds (fig. 16). Use one of the available ways:
 - press **POSITION RECOATER** (option available during the Onboarding process);
 - go to the **MAINTENANCE** menu ► **CONTROL PANEL** tab and control with the steering arrows.

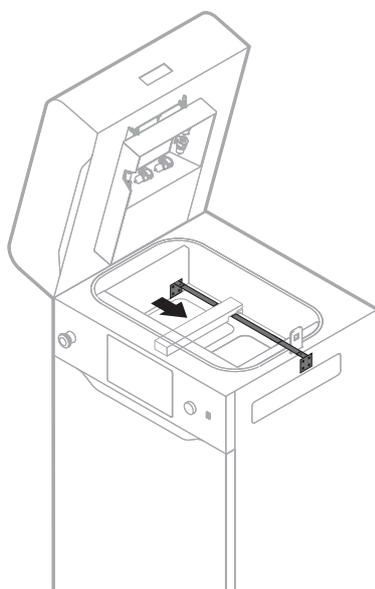

Fig. 16 Positioning the Recoater.

8. Similarly, position the second end of the Recoater strip to the angle bracket.
9. Using a 2.5 mm allen key and two Mx6 screws, pre-screw the Recoater strip onto the angles (fig. 17).

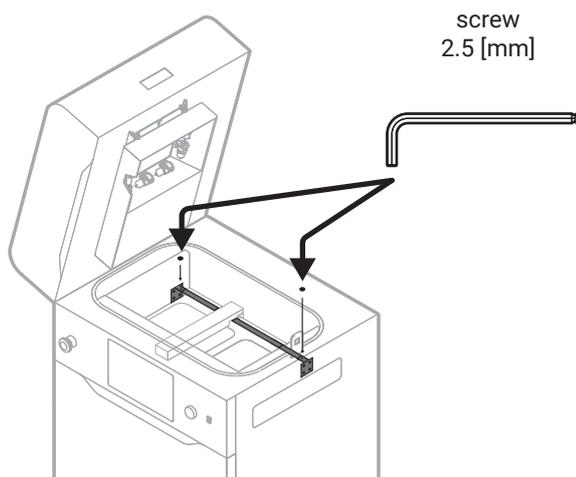

Fig. 17 Screwing on Recoater strip.

10. Check that the Recoater strip does not bend and tighten the screws to the end.
11. Using the steering arrows check that the Recoater moves smoothly along the Recoater strip.

1.3 SOFTWARE ACTIVATION ON THE PRINTER

1. On the screen under **SETTINGS**, select the **MORE OPTIONS** tab and then **RECOATER SETTINGS** (fig. 18).
2. Press the **CHANGE** button and the next window will appear.
3. Select the **RECOATER DRIVE TYPE** line and press the **CHANGE** button (fig. 18).
4. Select the **RECOATER STRIP** checkbox (fig. 19).
5. Read the message carefully then click on **GOT IT** and **SAVE**.
6. Now you can print using the Recoater Strip.

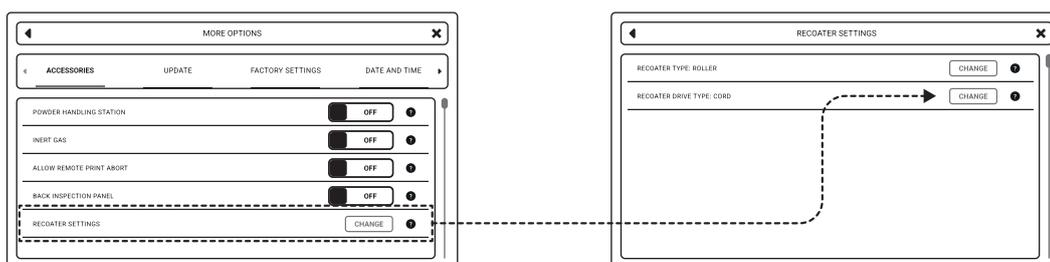

Fig. 18 Recoater Strip activation I.

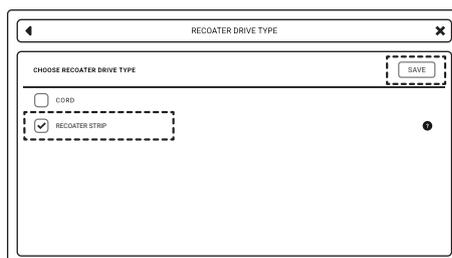
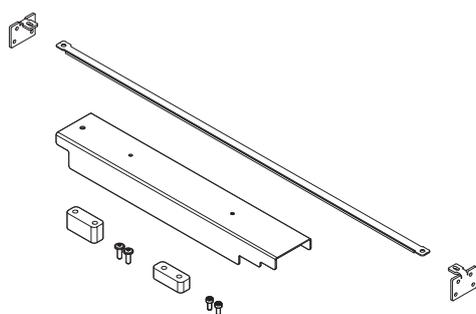

Fig. 19 Recoater Strip activation II.



SINTERIT Sp. z o.o.
ul. Nad Drwina 10/B-3, 30-741 Krakow, Poland
www.sinterit.com