

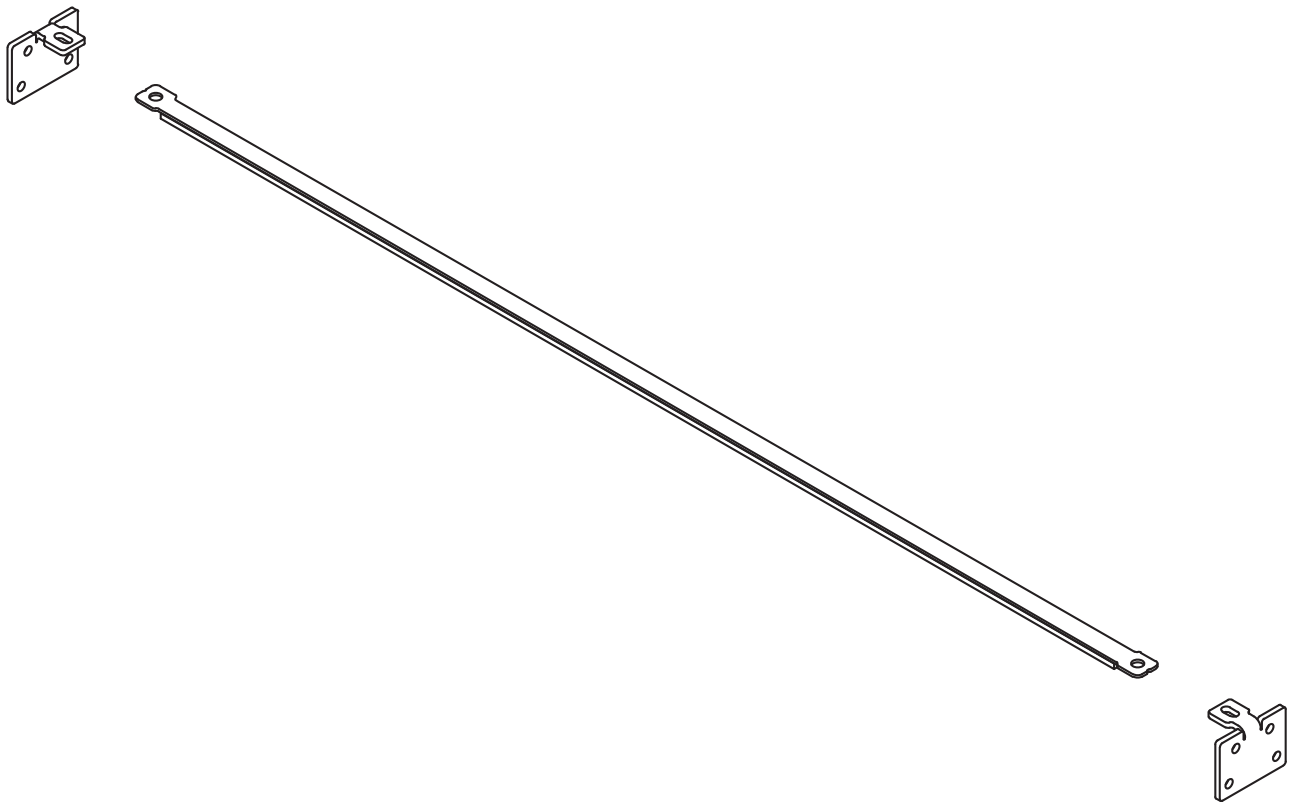

 SINTERIT

RECOATER STRIP

ASSEMBLY MANUAL



Version 04/2024/EN

LISA 



RECOATER STRIP INSTALLATION

1. Remove the Recoater strip from its packaging. Check that it is not damaged.
2. Slide the Recoater strip into the gap between the knurled roller and the Driver slider (Fig 1 & 2).



ATTENTION!

Don't bend the strip too much - it might break!

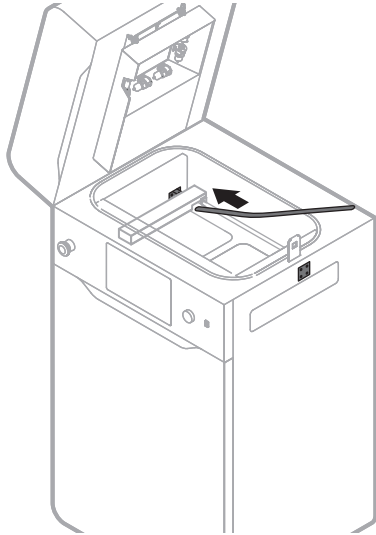

Fig. 1 Inserting Recoater strip to Recoater part 1.



Fig. 1 Inserting Recoater strip to Recoater part 2.

3. Mount the end of the Recoater strip under the angle bracket (fig. 3).



Fig. 3 Positioning the Recoater strip.

4. While holding the Recoater strip, position the Recoater in the middle, between the beds (fig. 4). Use one of the available ways:
 - a. press **POSITION RECOATER** (option available during the Onboarding process);
 - b. go to the **MAINTENANCE** menu ► **CONTROL PANEL** tab and control with the steering arrows.

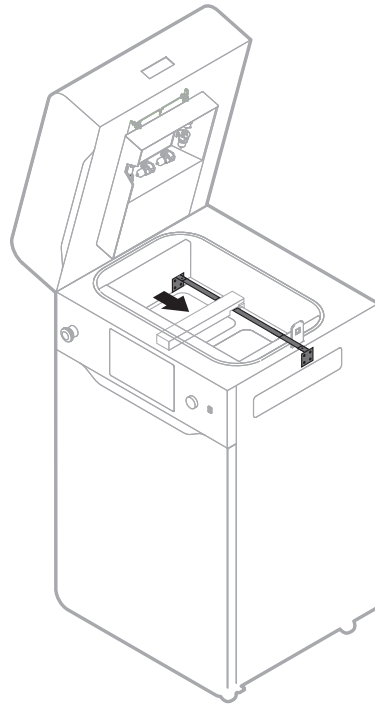

Fig. 4 Positioning the Recoater.

5. Similarly, position the second end of the Recoater strip to the angle bracket.
6. Using a 2.5 mm allen key, pre-screw the Recoater strip onto the angles (fig. 5).

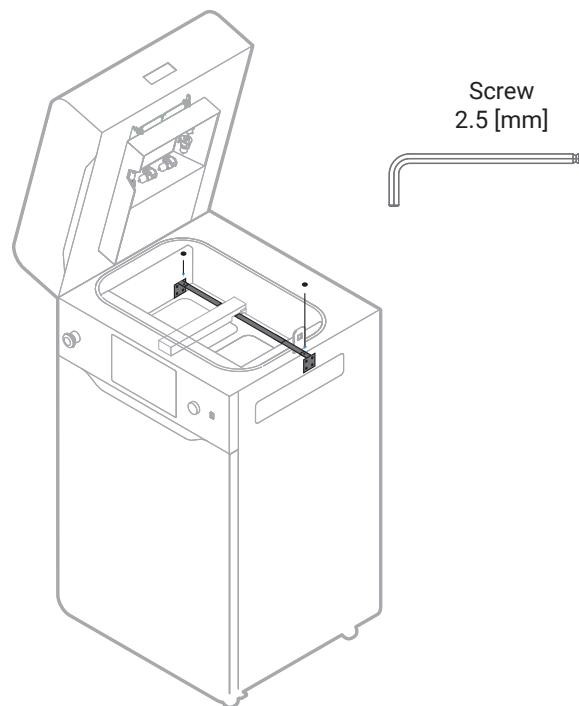
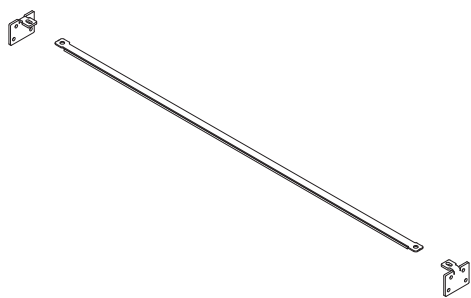

Fig. 5 Screwing on Recoater strip.

7. Check that the Recoater strip does not bend and tighten the screws to the end.
8. Using the steering arrows check that the Recoater moves smoothly along the Recoater strip.



SINTERIT Sp. z o.o.
ul. Nad Drwina 10/B-3, 30-741 Krakow, Poland
www.sinterit.com